



Watch Dog Series D115 NEMA 4X Duplex Control

FEATURES:

- Flashing Red Alarm Light
- 2 - Amber Run Lights
- High Decibel Audible (optional)
- NEMA 4X Fiberglass Enclosure
- Stainless Piano Hinged Door
- Stainless Door Latches w/Padlock Hasp
- External Mounting Feet
- 2 - 3 Pole, Non-Reversing Contactors
- 2 - "Hand/Off/Auto" Heavy Duty Toggles
- Alarm "On/Off/Test" Heavy Duty Toggle
- Field Wiring Terminal Strips
- 2 - Motor Circuit Breakers
- Control Circuit Breaker
- Individual 3 Amp Control/Alarm Circuit Fuses
- UL 508A Listing (optional)
- One Year Limited Warranty



D115P shown

APPLICATIONS INCLUDE:

- Starting & Stopping Pump for:
 - Sump & Sewage Basins
 - Septic Tanks & Aeration Systems
 - Cisterns & Atmospheric Storage Tanks
 - Chemical Solution Tanks
 - And Many More...

AVAILABLE OPTIONS:

- Piezo Buzzer
- Alarm Bell
- Vibrating Horn

(Automatic reset silence circuit included with all audibles)

UL 508A Listing

2 Hp. Max. - Motors With On-Winding Overload Protection

Specifications

| Model | Location Use | Max Full Load Amps | Enclosure Type | Enclosure Material | Input Power VAC -Ph | Audible Included | Alarm Fuse | Control Fuse | Approx Ship Weight |
|-------|--------------|--------------------|----------------|--------------------|---------------------|------------------|------------|--------------|--------------------|
| D115 | Outdoor | 12 | NEMA 4X | Fiberglass | 115-1 | --- | 3 Amp | 3 Amp | 18 lbs |
| D115P | Outdoor | 12 | NEMA 4X | Fiberglass | 115-1 | Piezo | 3 Amp | 3 Amp | 19 lbs |
| D115B | Outdoor | 12 | NEMA 4X | Fiberglass | 115-1 | Bell | 3 Amp | 3 Amp | 20 lbs |
| D115H | Outdoor | 12 | NEMA 4X | Fiberglass | 115-1 | Horn | 3 Amp | 3 Amp | 20 lbs |

*Add Suffix - FB to Model # If Ordering Float Switch and Float Switch Mounting Bracket Option
Float Kit Includes (4) MPF-0-10 Float Switches & (1) FSB-SS4 Float Switch Mounting Bracket

Can't Find What You Need Listed Above?

Remember CSI can custom build control panels to meet your specific needs!



Watch Dog Series D115 NEMA 4X Duplex Control

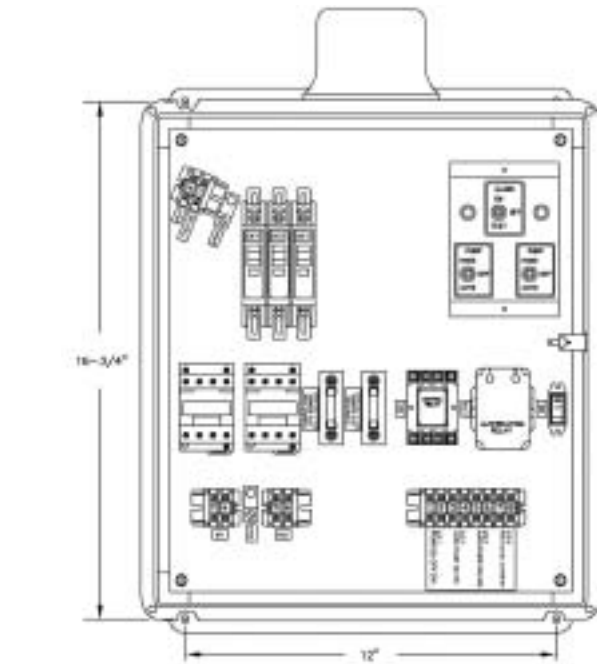
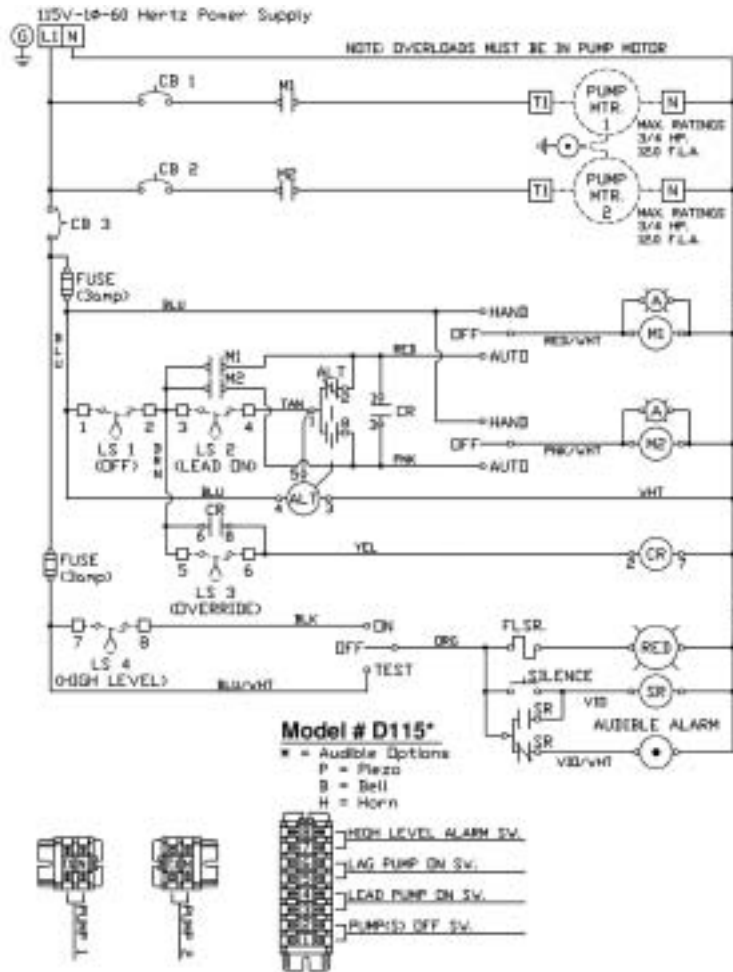

Model #D115 w/Audible

PIEZO AUDIBLE WILL BE MOUNTED THROUGH THE BOTTOM OF THE ENCLOSURE.
BELL OR HORN AUDIBLE WILL BE MOUNTED ON THE UPPER-RIGHT SIDE OF THE ENCLOSURE.

CONTROLS