



FEATURES:

- Flashing Red Alarm Light
- Amber Run Light
- High Decibel Audible (optional)
- NEMA 4X Fiberglass Enclosure
- Stainless Piano Hinged Door
- Stainless Door Latches w/Padlock Hasp
- External Mounting Feet
- 3 Pole, Non-Reversing Contactor
- Adjustable Overload Relay
- "Hand/Off/Auto" Heavy Duty Toggle
- Alarm "On/Off/Test" Heavy Duty Toggle
- Field Wiring Terminal Strips
- Motor Circuit Breaker
- Control Circuit Transformer - Primary Fusing
- Individual 3 Amp Control/Alarm Circuit Fuses
- UL 508A Listing (optional)
- One Year Limited Warranty

AVAILABLE OPTIONS:

Piezo Buzzer

Alarm Bell

Vibrating Horn

(Automatic reset silence circuit included with all audibles)

UL 508A Listing



S233P shown

APPLICATIONS INCLUDE:

Starting & Stopping Pump for:
 Sump & Sewage Basins
 Septic Tanks & Aeration Systems
 Cisterns & Atmospheric Storage Tanks
 Chemical Solution Tanks
 And Many More...

No Motor Heat Sensor
or Seal Fail Probes

Specifications

Model	Location Use	Max Full Load Amps	Enclosure Type	Enclosure Material	Input Power VAC -Ph	Audible Included	Alarm Fuse	Control Fuse	Approx Ship Weight
S233	Outdoor	18	NEMA 4X	Fiberglass	230-3	---	3 Amp	3 Amp	13 lbs
S233P	Outdoor	18	NEMA 4X	Fiberglass	230-3	Piezo	3 Amp	3 Amp	13 lbs
S233B	Outdoor	18	NEMA 4X	Fiberglass	230-3	Bell	3 Amp	3 Amp	14 lbs
S233H	Outdoor	18	NEMA 4X	Fiberglass	230-3	Horn	3 Amp	3 Amp	15 lbs

**Add Suffix For FLA Requirement (See table on next page)

*Add Suffix - FB to Model # If Ordering Float Switch and Float Switch Mounting Bracket Option
Float Kit Includes (3) MPF-0-10 Float Switches & (1) FSB-SS3 Float Switch Mounting Bracket



Watch Dog Series S233 NEMA 4X Simplex Control

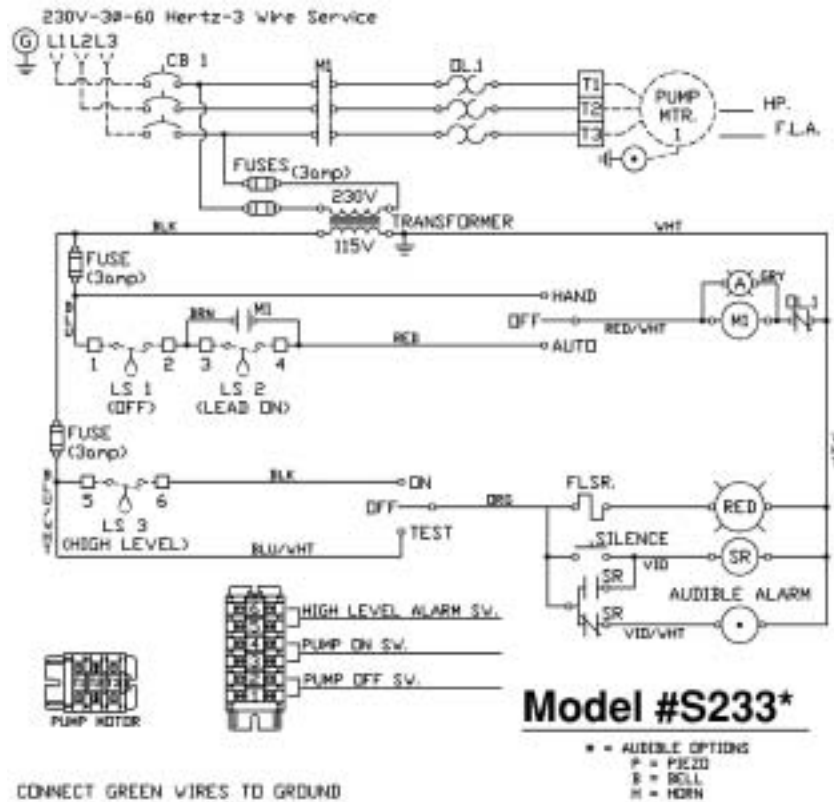

CONTROLS

****Important****

This "Watchdog" Series panel is for small effluent type pumps only. No provisions for motor heat sensors or seal probes are provided. When ordering any of the above panels, match the full-load-amperes (FLA), of the pump(s) you are using to the chart below and add the proper suffix to the model number. EXAMPLE: You need a simplex control panel with alarm light and bell - your pump is 230 V with FLA rating of 5 - Order Model #S233B-10 for panel only or Model #S233B-10-FB if you want the float kit included

****FLA Rating Table**

FLA	Suffix	FLA	Suffix
.063-1.0	-05	5.5 - 8	-12
1.0 - 1.7	-06	7 - 10	-14
1.6 - 2.5	-07	9 - 13	-16
2.5 - 4	-08	12 - 18	-21
4 - 6	-10		

