

FEATURES:

- Flashing Red Alarm Light
- 2 - Run Lights
- High Decibel Audible (optional)
- NEMA 4X Fiberglass Enclosure
- Stainless Piano Hinged Door
- Stainless Door Latches w/Padlock Hasp
- External Mounting Feet
- Automatic Alternating Relay/Override Circuit
- 2 - 3 Pole, Non-Reversing Contactors
- 2 - Adjustable Overload Relays
- 2 - Hand Run Pushbuttons
- Alarm Test/Silence Pushbutton
- Field Wiring Terminal Strips
- 2 - Motor Circuit Breakers
- Control Circuit Transformer - Primary Fusing & Breaker
- Individual Control/Alarm Circuit Fuses
- UL 508A Listing (optional)
- One Year Limited Warranty

See Page 15 to learn about the Advantages of the Titan Float System!



APPLICATIONS INCLUDE:

- Starting & Stopping Pump for:
 - Sump & Sewage Basins
 - Septic Tanks & Aeration Systems
 - Cisterns & Atmospheric Storage Tanks
 - Chemical Solution Tanks
 - And Many More...

No Motor Heat Sensor or Seal Fail Probes

AVAILABLE OPTIONS:

- Piezo Buzzer
- (Automatic reset silence circuit included with all audibles)
- Digital Display Center
- UL 508A Listing

Specifications

| Model | Location Use | Max Full Load Amps | Enclosure Type | Enclosure Material | Input Power VAC -Ph | Audible Included | Alarm Fuse | Control Fuse | Approx Ship Weight |
|---------|--------------|--------------------|----------------|--------------------|---------------------|------------------|------------|--------------|--------------------|
| TDF233 | Outdoor | 18 | NEMA 4X | Fiberglass | 230-3 | --- | 3 Amp | 3 Amp | 21 lbs |
| TDF233P | Outdoor | 18 | NEMA 4X | Fiberglass | 230-3 | Piezo | 3 Amp | 3 Amp | 21 lbs |

**Add Suffix For FLA Requirement (See table on next page)

*Add Suffix - FB to Model # If Ordering Float Switch and Float Switch Mounting Bracket Option

Float Kit Includes (4) MPF-0-10 Float Switches & (1) FSB-SS4 Float Switch Mounting Bracket
To include elapsed time meters & cycle counters a digital display may also be added

**FLA Rating Table

****Important****

This Titan Series panel is for small effluent type pumps only. No provisions for motor heat sensors or seal probes are provided. When ordering any of the above panels, match the full-load-amperes (FLA), of the pump(s) you are using to the chart to the right and add the proper suffix to the model number. EXAMPLE: You need a duplex control panel with alarm light and Piezo - your pumps are 230 V with FLA rating of 5 - Order Model #TDF233P-10 for panel only or Model #TDF233P-10-FB if you want the float kit included

| FLA | Suffix | FLA | Suffix |
|-----------|--------|---------|--------|
| .063-1.0 | -05 | 5.5 - 8 | -12 |
| 1.0 - 1.7 | -06 | 7 - 10 | -14 |
| 1.6 - 2.5 | -07 | 9 - 13 | -16 |
| 2.5 - 4 | -08 | 12 - 18 | -21 |
| 4 - 6 | -10 | | |



Titan Series

TDF233 Duplex Float

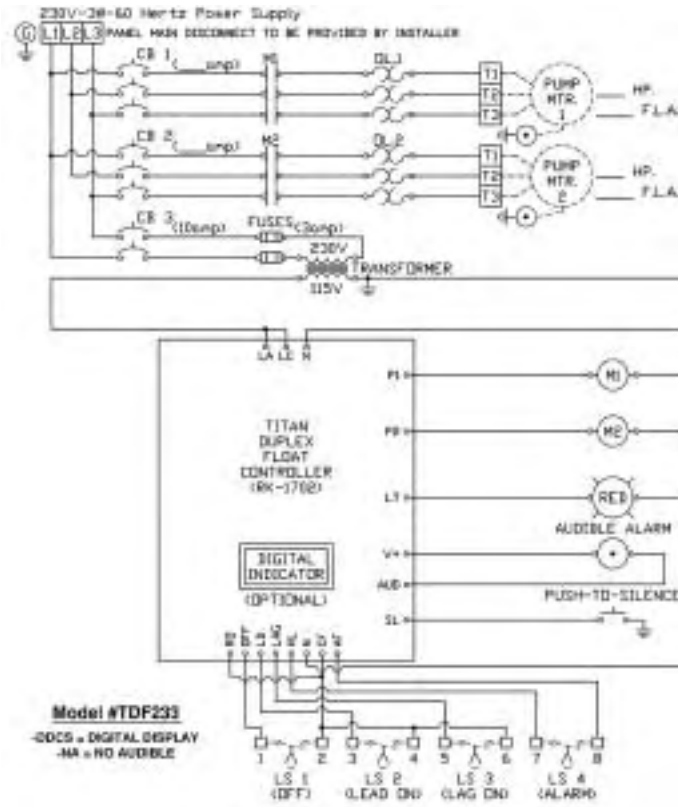

CONTROLS

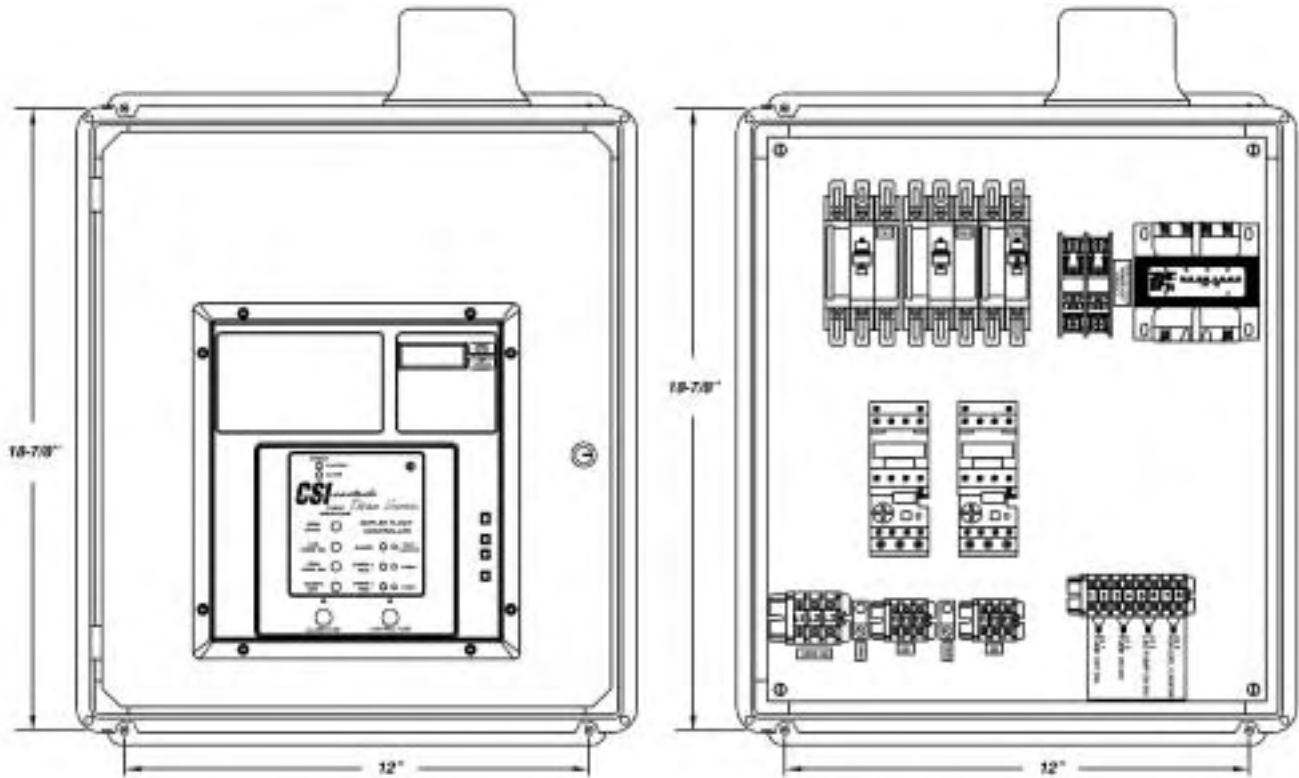

Model #TDF233 w/Audible

AUDIBLE ALARM WILL BE MOUNTED THROUGH THE BOTTOM OF THE ENCLOSURE