

CSI Titan Series TDP233 Duplex Pressure

FEATURES:

- Flashing Red Alarm Light
- 2 - Run Lights
- High Decibel Audible (optional)
- NEMA 4X Fiberglass Enclosure
- Stainless Piano Hinged Door
- Stainless Door Latches w/Padlock Hasp
- External Mounting Feet
- Automatic Alternating Relay/Override Circuit
- 2 - 3 Pole, Non-Reversing Contactors
- 2 - Adjustable Overload Relays
- 2 - Hand Run Pushbuttons
- Alarm Test/Silence Pushbutton
- Field Wiring Terminal Strips
- 2 - Motor Circuit Breakers
- Control Circuit Transformer - Primary Fusing & Breaker
- Individual Control/Alarm Circuit Fuses
- UL 508A Listing (optional)
- One Year Limited Warranty

See Page 16 to learn about the Advantages of the Titan Pressure System!



APPLICATIONS INCLUDE:

Starting & Stopping Pump for:
 Sump & Sewage Basins
 Septic Tanks & Aeration Systems
 Cisterns & Atmospheric Storage Tanks
 Chemical Solution Tanks
 And Many More...

No Motor Heat Sensor or Seal Fail Probes

AVAILABLE OPTIONS:

Piezo Buzzer

(Automatic reset silence circuit included with all audibles)

Digital Display Center

UL 508A Listing

Specifications

Model	Location Use	Max Full Load Amps	Enclosure Type	Enclosure Material	Input Power VAC -Ph	Audible Included	Alarm Fuse	Control Fuse
TDP233	Outdoor	18	NEMA 4X	Fiberglass	230-3	---	3 Amp	3 Amp
TDP233P	Outdoor	18	NEMA 4X	Fiberglass	230-3	Piezo	3 Amp	3 Amp

**Add Suffix For FLA Requirement (See table below)

*Add Suffix - "MB" to Model # If Ordering Pressure Bell Mounting Bracket or "TK" for a Tether Kit

The system comes standard with a pressure bell and 50ft of tubing. More tubing is available

To include elapsed time meters, cycle counters, and level read out a digital display may also be added

**FLA Rating Table

****Important****
 This Titan Series panel is for small effluent type pumps only. No provisions for motor heat sensors or seal probes are provided. When ordering any of the above panels, match the full-load-amperes (FLA), of the pump(s) you are using to the chart to the right and add the proper suffix to the model number. EXAMPLE: You need a duplex control panel with alarm light and Piezo - your pump is 230 V with FLA rating of 5 - Order Model #TDP233P-10 for panel only or Model #TDP233P-10-MB if you want the mounting bracket included

FLA	Suffix	FLA	Suffix
.063-1.0	-05	5.5 - 8	-12
1.0 - 1.7	-06	7 - 10	-14
1.6 - 2.5	-07	9 - 13	-16
2.5 - 4	-08	12 - 18	-21
4 - 6	-10		

CSI Titan Series TDP233 Duplex Pressure

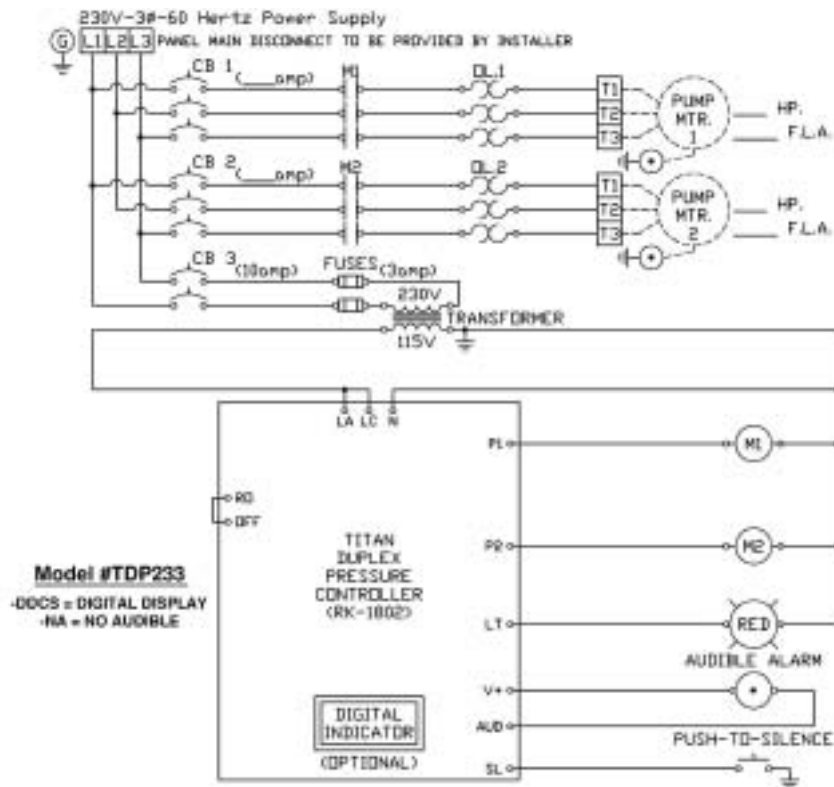

CONTROLS

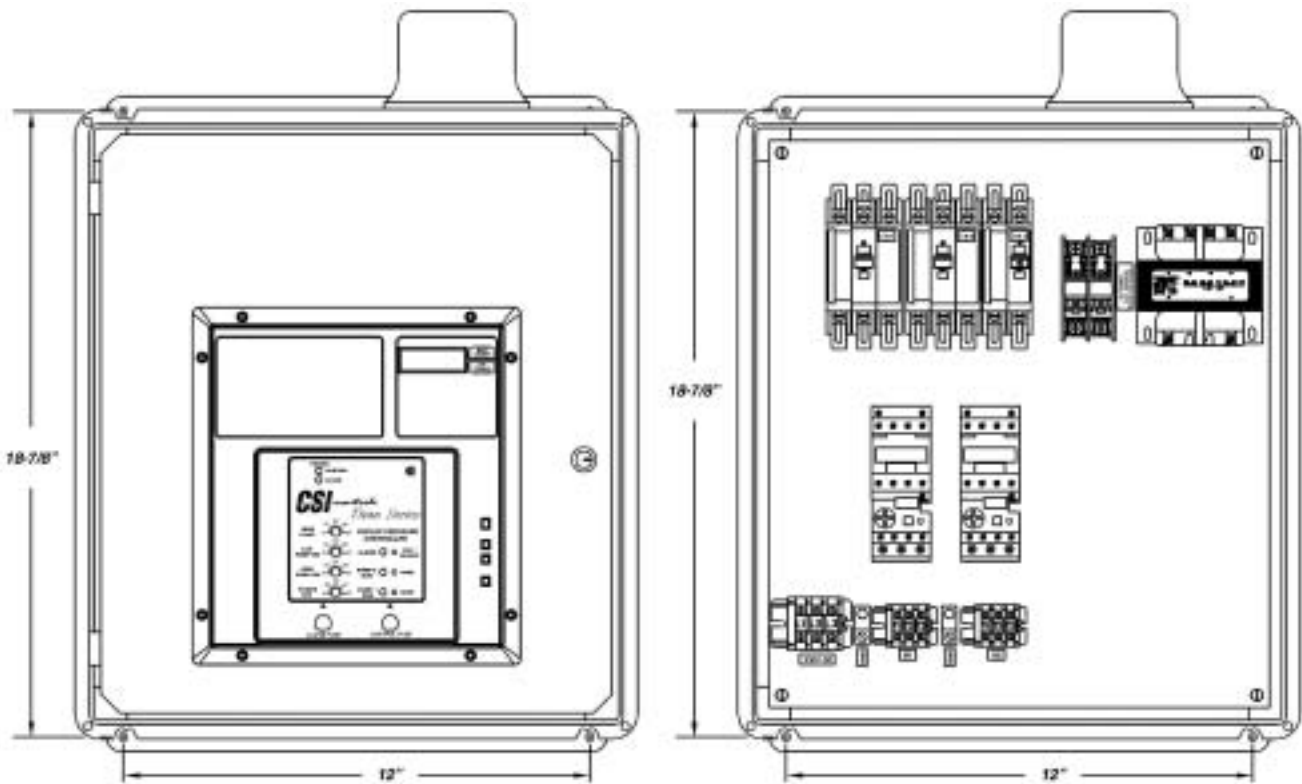

Model #TDP233 w/Audible

AUDIBLE ALARM WILL BE MOUNTED THROUGH THE BOTTOM OF THE ENCLOSURE